

SNP-HF3 Series

30 W AC/DC Switch Mode Power Supplies – Open Frame

CoolPower
Solutions

- 1.57" x 2.76" x 0.9" compact size
- Flexible installation for Class I/II
- -40°C to 70°C convection cooling
- Operation from -20°C to 70°C
- Up to 12,000uF loading start-up
- Eco-friendly design



Electrical specifications

| | | |
|---------------|---------------------------|---|
| Input | Voltage | 90-264 VAC |
| | Frequency | 47-63 Hz |
| | Inrush Current | < 80 A at 230 VAC, cold start, 25°C |
| Output | Output Power | 30 W, Max. 40 W, Peak 45 W |
| | Voltage (VDC) | See table below |
| | Current (A) max. | See table below |
| | Efficiency | Average 86% (A-Models 80%) |
| | Hold-up Time | 16 ms typical |
| Protection | No-load power consumption | < 0.5 W |
| | Over Load Protection | Auto recovery |
| | Over Voltage Protection | Latch off |
| Environment | Short Circuit Protection | Auto recovery |
| | Operating Temperature | -40°C ... +70°C (derating: 2.5% / °C > 50°C) |
| | Storage Temperature | -40°C ... +85°C |
| Physical | Humidity | 5% to 90% RH, non-condensing |
| | Dimension (L x W x H) | 40 x 70 x 23 mm |
| | Weight | 130 g |
| | Cooling | Convection cooling, Max. 36W for forced air cooling |
| Safety & EMC | Connections | AC input: JST B2P3-VH or equivalent DC output: JST B2P-VH or equivalent |
| | EMI | EN55011 "B", EN61000-3-3 |
| | Harmonics | EN61000-3-2, class A |
| | EMS | EN61000-4-2,-3,-4,-5,-6,-8,-11 |
| Energy Saving | Safety Approvals | UL/CSA/EN60950-1, 2nd edition ANSI/AMMI/CSA/EN60601-1, 3rd edition CB report, CE mark, RM report/file |
| | | Energy Star v.6 ErP regulation EC (No) 1275/2008 |

Applications

Suitable for dental, laboratory products, pumps, monitors, sleep apnea devices and many other uses.

SNP-HF3 Series

30 W AC/DC Switch Mode Power Supplies – Open Frame

CoolPower
Solutions

Models

| Model | Output | Load | | | | Initial accuracy* | Step Efficiency | | | Average Efficiency |
|------------|--------|------|--------|--------|-------|-------------------|-----------------|-----|------|--------------------|
| | | Min | Rated | Max | Peak | | 20% | 50% | 100% | |
| SNP-HF37 | +12 V | 0 A | 2,5 A | 3.0 A | 3.8 A | +11.9V~+12.1V | 86% | 87% | 86% | 86% |
| SNP-HF37-A | +12 V | 0 A | 2.5 A | 3.0 A | 3.8 A | +11.9V~+12.1V | 76% | 83% | 84% | 80% |
| SNP-HF38 | +15 V | 0 A | 2.0 A | 2.4 A | 3.0 A | +14.9V~+15.1V | 86% | 87% | 86% | 86% |
| SNP-HF38-A | +15 V | 0 A | 2.0 A | 2.4 A | 3.0 A | +14.9V~+15.1V | 76% | 83% | 84% | 80% |
| SNP-HF39 | +24 V | 0 A | 1.25 A | 1.5 A | 1.9 A | +23.8V~+24.2V | 86% | 87% | 86% | 86% |
| SNP-HF39-A | +24 V | 0 A | 1.25 A | 1.5 A | 1.9 A | +23.8V~+24.2V | 76% | 83% | 84% | 80% |
| SNP-HF3T | +48 V | 0 A | 0.63 A | 0.75 A | 1.0 A | +47.6V~+48.4V | 86% | 87% | 86% | 86% |
| SNP-HF3T-A | +48 V | 0 A | 0.63 A | 0.75 A | 1.0 A | +47.6V~+48.4V | 76% | 83% | 84% | 80% |

Notes

1. Output Load:

Rated 30W for convection cooling; max. 36W for forced air cooling.

2. Peak Load Duration:

Peak 45W can last for 5 sec. especially suitable for motor starting.

3. Engineering Specification:

Detailed specification and relative test method are mentioned in engineering specification. For business, engineering specification by model must be used.

4. Standby Power Consumption with System:

This is required by ENERGY STAR in U.S. and ErP regulation in Europe for appliances such as computers and displays. The latest requirement is measured input power to be less than 0.5W with system.

5. Audible Noise:

To meet standby power consumption requirement, there are two ways depend on current technology. One is frequency reduction; another one is burst.

However, since both of the operating frequency will move into audio frequency, the audible noise could be observed.

6. Step Efficiency and Average Efficiency:

Test conditions in step efficiency are referred to 3.2.2 IPS (Internal Power Supply) of ENERGY STAR program requirements for computers. ENERGY STAR required for efficiency @ 20%, 50%, 100% load is 82%, 85%, 82%; average efficiency is the average of step efficiency.

7. Class I/II Installation:

From safety point of view, the isolation of Class II (without safety ground) is stricter than that of Class I (with safety ground). So PSU could be designed to meet Class II safety. But for EMC, it depends. So PSU has to be tested with both installations.

8. Model Ordering Table:

| Safety: | Application w/o Audible Noise | Application Energy Saving |
|---------------|-------------------------------|---------------------------|
| ITE & Medical | SNP-HF3x-A | SNP-HF3x |

Dimensions

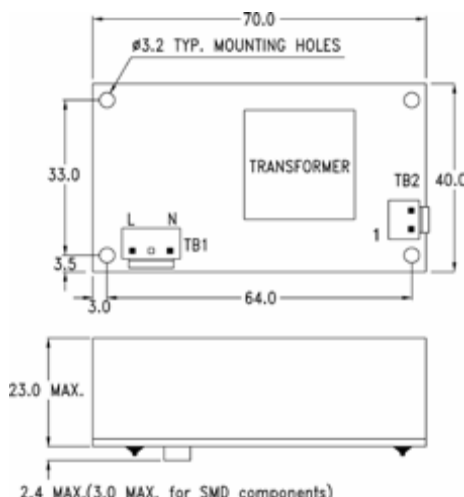

Output Pin assignment:

| Pin No. | 1 | 2 |
|----------|------|-----|
| SNP-HF37 | +12V | GND |
| SNP-HF38 | +15V | GND |
| SNP-HF39 | +24V | GND |
| SNP-HF3T | +48V | GND |